

Product Highlights

Mantall super material lift is a power-free, manually operated material lift. It is compact, lightweight, highly mobile, can easily pass through standard doorways, and can be easily loaded and unloaded.

SML series material lift can be widely used in construction, industry, warehousing, exhibitions, stage construction, advertising, central air-conditioning ducts and other high-altitude installations.



Standard Features

Standard forks	Roller wheels with brake
Incorporates a silent ratchet system	Telescopic mast design
Transportation wheels	Solid steel base
Anti-fall function	

Options Features

Adjustable forks	Boom
Flat forks	Load platform



Model	SML-20	
Dimension	Metric	Imperial
Standard forks - up m H1	6.45m	21ft 2in
Standard forks - down m H2	5.93m	19ft 5in
Adjustable forks - up m	6.45m	21ft 2in
Adjustable forks - down m	5.93m	19ft 5in
Flat forks m	—	—
Height - stowed m D	2.05m	6ft 9in
Length - stowed m G	0.77m	2ft 6in
Length - operating m E	2.2m	7ft 3in
Width - stowed*m F	0.79m	2ft 7in
Stabilizers lowered m	1.9m	6ft 3in
Ground clearance - center m H	0.05m	0ft 2in
Load height minimum m	0.15m	0ft 6in
Productivity		
Load capacity	230kg	573lb
Power	Single speed winch	Single speed winch
Weight kg	203kg	448lb

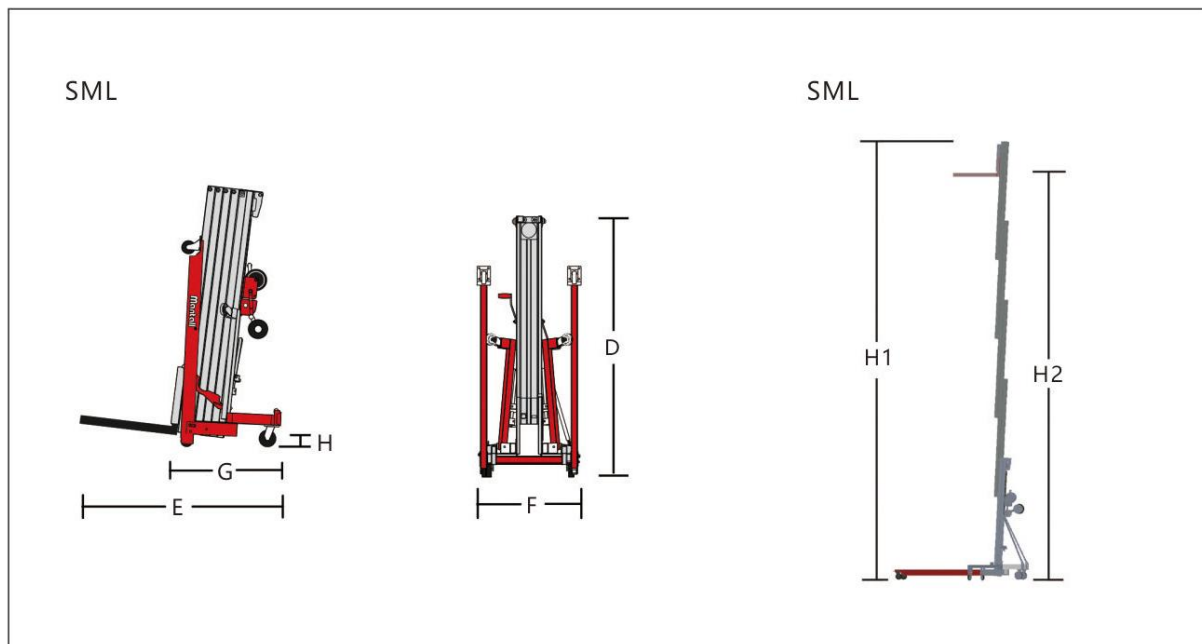

The images in this manual are for illustration only, and all copyrights belong to our company. Due to continuous technological updates, product parameters may change without prior notice.

